

### SPECIFICATIONS

Size	Metric	British
Max. Working Height	16.27m	53ft 4in
Max. Platform Height	14.27m	46ft 10in
Max. Operating Range(+0.6m)	8.69m	28ft 6in
Max. Platform Range	8.09m	26ft 6in
Flatbed Transport Dimensions (L×W×H)	5.17m×2.44m×2.58m	16ft11in×8ft×8ft 5in
Standard Container Transport	All Applicable	All Applicable
Platform Size(Length×Width)	1.83m×0.79m	6ft×2ft 7in
Turntable Tailswing	0	0
Ground Clearance <b>A</b>	0.31m	1ft
Wheelbase <b>B</b>	2.40m	7ft 10in
Turning Radius(Inside/Outside)	3m/4.73m	9ft 10in/15ft 6in
Tyres	315/55 D20	315/55 D20
Max. Up And Over Clearance	7.30m	23ft 11in
Max. Down Probing Depth	0.42m	1ft 4in

Performance		
S.W.L	320kg	705lb
Max. Occupants	2	2
Gradeability	40%	40%
Travel Speed(Stowed)	6.0km/h	3.7mph
Travel Speed(Raised)	1.1km/h	0.7mph
Max. Working Slope	X-5°/Y-5°	X-5°/Y-5°
Turret Rotation	360°Continuous	360°Continuous
Platform Rotation	180°	180°
Jib Movement	132°	132°

Weight		
Overall Weight	8300kg	18298lb

Power		
Battery	48V/375Ah	48V/375Ah
Charger	48VDC/60A	48VDC/60A
Driving Motor	34AC/9kW	34AC/9kW
Lifting Motor	34VAC/13kW	34VAC/13kW
Hydraulic Tank	145L	38gal

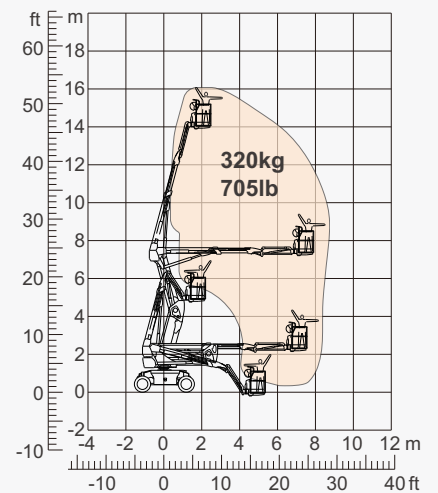

Range Of Motion

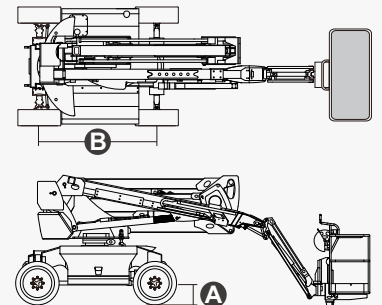

## FEATURES

### Standard Items

- 1.50m (4ft 11in) Jib
- Front Oscillating Axle
- Two-Wheel Steering
- Four-Wheel Drive
- Self-Leveling Platform
- 180° Left And Right Swing Platform
- Proportional Joystick Controls
- Thumb Rocker Steer
- Drive Enable
- Ac Power Cord To Platform
- Tilt Alarm
- Descent Alarm
- Flash
- Horn
- Hour Meter
- Integral Integrated Special Drive Axle  
For Construction Machinery
- 360° Continuous Turntable Rotation
- Positive Traction Four Wheel Drive
- Platform Load Sense System
- Fault Diagnosis System
- Operator Anti-crushing Protection System
- Harsh Environment Kits
- 12V DC Auxiliary Power
- Battery 375Ah/48V
- Driving Motor 9kW 4834rpm
- Lifting Motor 13kW 1855rpm



Articulated  
Boom-BA



Working  
Height-16m



Jib



Electric-E



Rough  
Terrain-RT



### ZHEJIANG DINGLI MACHINERY CO., LTD.

Address: No.188 Qihang Road,Deqing,Zhejiang P.R.C 313219

Telephone: +86(572)8681688

E-Mail: [export@cndingli.com](mailto:export@cndingli.com)

[Https://en.cndingli.com](https://en.cndingli.com)

Due to continuous technology updates, technical parameters are subject to change without notice. This picture book is for reference only, the actual product shall prevail. The copyright is owned by zhejiang dingli, any content may not be copied for any purpose without written permission.

2023-07

